

**AOYUE<sup>®</sup> 937/ 937+**

**Temperature Controlled  
Soldering Station**

**Instruction Manual**

Thank you for purchasing Aoyue 937 / 937+  
temperature controlled soldering station.  
Please read the manual before using the unit.  
Keep manual in accessible place for future reference.

Manufacturer:

**AOYUE TONGYI ELECTRONIC EQUIPMENT FACTORY**

Jishui Industrial Zone, Nantou, Zhongshan City,

Guangdong Province, P.R.China

<http://www.aoyue.com>

# REPLACEMENT SOLDERING TIPS

## Conical Type

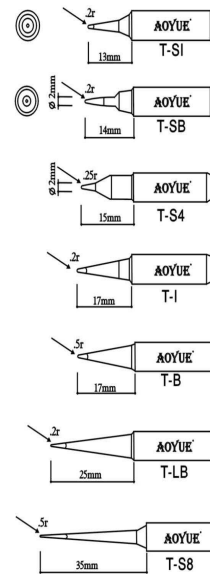

## Sharp-Bent Type

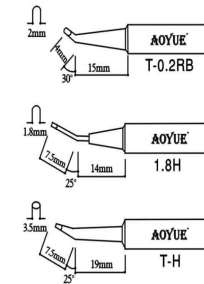

## Blade Type

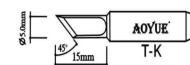

## Bevel Type

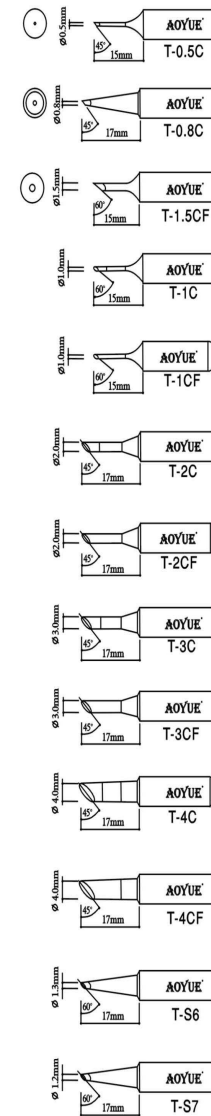

## Chisel Type

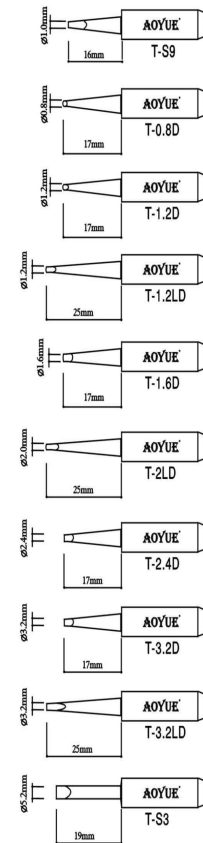

## Slot Type

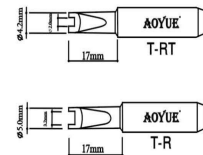

## BASIC TROUBLESHOOTING GUIDE

---

### **PROBLEM 3: Soldering iron temperature is intermittent.**

**Description:** *Display lights up but soldering iron temperature rises and falls uncontrollably.*

#### **SOLUTION:**

- ◆ Soldering iron plug may be loose from the receptacle unplug the soldering iron and reattach.
- ◆ Soldering iron cord may be damaged or loose and needs to be replaced or repaired. See trouble shooting soldering iron cords section of this manual.

### **PROBLEM 4: The solder would not stick to the soldering pen.**

**Description:** *Soldering iron is able to quickly melt solder but cannot cause the solder to attach to the tip.*

#### **SOLUTION:**

- ◆ Soldering iron tip may already be too dirty or oxidized . Please see our solder tip maintenance guide on how to clean soldering tips.
- ◆ Temperature could be set too high causing solder to quickly burn away, Please adjust to a more suitable lower temperature range.

### **PROBLEM 5: Display and other problems not mentioned.**

**Description:** *Display shows unreadable characters.*

#### **SOLUTION:**

- ◆ Press the reset button or turn the unit off and then back on after a few seconds.

## **TABLE OF CONTENTS**

<b>Package Contents and Specifications.....</b>	<b>4</b>
<b>Care and Safety Precautions .....</b>	<b>5</b>
<b>Assembly Instructions .....</b>	<b>6</b>
<b>Operating Instructions .....</b>	<b>7</b>
<b>Soldering Tip Care and Maintenance .....</b>	<b>8</b>
<b>Tip Temperature</b>	
<b>Cleaning</b>	
<b>When not in use</b>	
<b>Hand piece Assembly .....</b>	<b>9</b>
<b>Testing the heating element .....</b>	<b>10</b>
<b>Troubleshooting Connections .....</b>	<b>11</b>
<b>Replacing soldering iron cord / Fuse .....</b>	<b>12</b>
<b>Basic Troubleshooting Guidelines .....</b>	<b>13-14</b>
<b>Replacement Soldering Tips .....</b>	<b>15</b>

## PACKAGE CONTENTS/ SPECIFICATIONS

Please check if the listed parts below are included in the package:

### Aoyue 937/937+

937 Main Station	.....	1 unit
Soldering Iron	.....	1 pc.
Soldering Iron Stand		
(including Sponge)	.....	1 pc.
Instruction Manual	.....	1 pc.
Power Cord	.....	1 pc.

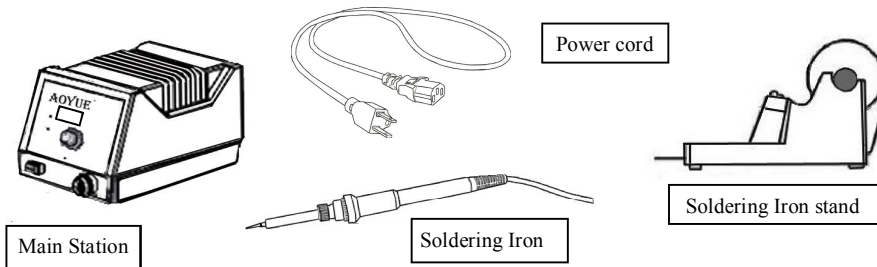

937 / 937+	
<b>Power Consumption</b>	<b>45W</b>
<b>Fuse</b>	<b>1A</b>
<b>Output Voltage</b>	<b>24V</b>
<b>Temperature Range</b>	<b>200—480 °C / 392—896°F</b>
<b>Dimension</b>	<b>110(w)×93(l)×168(h) mm</b>
<b>Tip to Ground Resistance</b>	<b>Less than 2 Ohm</b>
<b>Heating Element</b>	<b>Ceramic Heating Element</b>

\*Design and specification might change without prior notice.

## BASIC TROUBLESHOOTING GUIDE



**WARNING:** To avoid personal injury or equipment damage, disconnect power cords before making any servicing to the equipment, or unless instructed otherwise in the troubleshooting procedures.

### **PROBLEM 1: The unit has no power / display does not light up.**

1. Check if the unit is switched ON.
2. Check the fuse. Replace with the same type of fuse if blown.
3. Check the power cord and make sure there are no disconnections.
4. Verify that the unit is properly connected to the power source.

Additional precautions :

- ◆ Check internal circuitry for shorts that may cause the blown fuse. See "[Troubleshooting Connections](#)".
- ◆ Check for tangles of wires in the heating element causing it to short. See "[Troubleshooting Connections](#)".

### **PROBLEM 2: The temperature of the soldering iron is not rising.**

**Description:** Display lights up but soldering iron temperature is relative low and is not heating up.

#### **SOLUTION:**

Soldering iron cord may be damaged and needs to be replaced or repaired. See "[Troubleshooting Connections](#)" of this manual.

Heating element may be damaged and needs to be replaced see "[Testing the Heating Element](#)" and "[Replacing the Heating Element](#)" on this manual.

## REPLACING SOLDERING IRON CORD / FUSE

### When cord is proven to be faulty follow the steps to replace the cord:

1. Follow the steps in disassembling the hand piece.
2. Make a brief illustration of wire configuration in the PCB.
3. Unsolder the wires connecting the hand piece PCB and cord together.
4. Unattached the grounding cord and grounding spring together.
5. Detach the PCB from the cord by releasing the metal grips located at the bottom of the PCB .
6. Slide out the main handle , soft grip pad and tail end of the hand piece.
7. Insert the tail end and soft grip pad into the new cord.
8. Insert the new cord thought the main handle.
9. Solder the wires back into the PCB.
10. Reattach grounding spring to the new cord.
11. Bend the metal on the end of the PCB to grip the cord firmly.
12. Follow Reassembly of hand piece steps to complete the process.

### Checking/ Changing the fuse:

The Fuse can be found at the back of the unit, it is incorporated into the AC power receptacle. If fuse is blown replace with same type fuse only.

1. Use a screw driver to pop open the fuse holder, slide the fuse holder out
2. Check if the fuse in use is blown. If blown/damaged, detach the spare fuse and attach to the active fuse holder. )
3. Reattach the fuse holder.

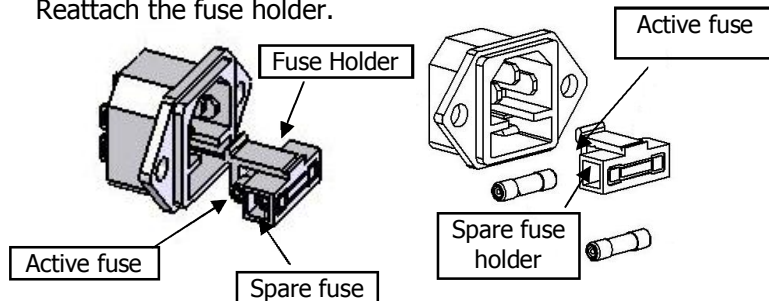

## CARE and SAFETY PRECAUTIONS



**CAUTION: Misuse may cause injury and physical damage.**  
For your own safety, be sure to comply with the following precaution.

- Temperature may reach a high of 480°C when turned on.
  - Do not use near inflammable/flammable materials.
  - Do not touch heated parts, can cause severe burns.
  - Do not touch metallic parts near the Tip.
- Thermal Protector
  - Unit is equipped auto shut-off ability when temperature gets too high and automatically turns on when temperature dropped to a safe level.
- Handle with Care
  - Never drop or sharply jolt the unit.
  - Contains delicate parts that may break if unit is dropped.
- Disconnect plug when not to be used for a long period of time.
  - Turn off power during breaks.
- Use only genuine replacement parts.
  - Turn-off power and let unit cool before replacing parts.
- Soldering process produces smoke, make sure work area is well ventilated.
- Do not modify unit
- Never touch the element or tip of the soldering iron. They are very hot (about 400°C) and will give you a nasty burn.
- Take great care to avoid touching the mains flex with the tip of the iron. The iron should have a heatproof flex for extra protection. An ordinary plastic flex will melt immediately if touched by a hot iron and there is a serious risk of burns and electric shock.
- Always return the soldering iron to its stand when not in use.
- Work in a well-ventilated area. The smoke formed as you melt solder is mostly from the flux and is quite irritating. Avoid breathing it by keeping your head on the side and not directly above of your work.
- Wash your hands after using solder. Solder may contain lead which is a poisonous metal.

# ASSEMBLY INSTRUCTIONS

## I. SOLDERING IRON HOLDER

1. Install solder wire to the solder iron holder. (Fig. 1)
2. Dampen the cleaning sponge with water, squeeze it dry and place it in its base. (Fig. 2)

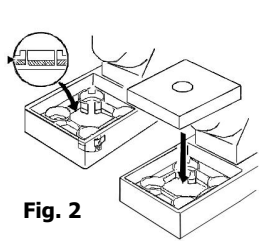

Fig. 2

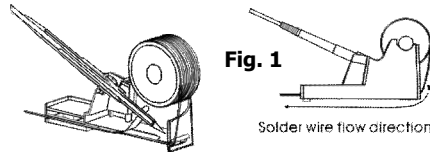

Fig. 1

Solder wire flow direction

⚠ Failure to dampen sponge might damage the soldering tip.

## II. SOLDERING IRON

1. Attach the soldering iron to the receptacle connector at the bottom right area of the main unit.
2. Place soldering iron to the soldering iron stand as shown in Fig. 1

⚠ Soldering iron must be placed in the iron holder when not in use.

## III. MAIN UNIT CONTROLS

1. Plug the power cord into a receptacle with ground.

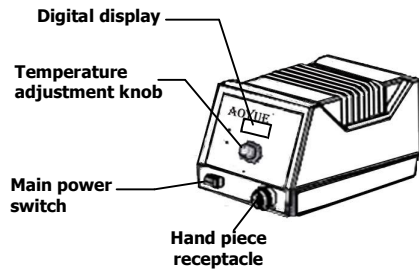

937 Controls

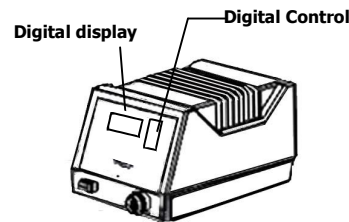

937+ Controls

# TROUBLESHOOTING CONNECTIONS

**The 5 pin socket can be tested to detect faults in the handpiece:**

Pins 4 & 2	∞
Pins 4 & 1	∞
Pins 5 & 1	∞
Pins 5 & 2	∞

Before plugging in the hand piece conduct the continuity test as shown:

If any of the combination registers a short re-view the steps in "replacing the heating element" to ensure proper connections.



Warning: Ensure none of the above mentioned conditions are present before plugging in the hand piece. Failure to do so can damage the internal circuitry of the unit.

**Follow the following direction to test for hand piece cord faults:**

### Test 1: Rendering physical strain to the cord

1. Turn on the unit.
2. Set temperature to 480 °C.
3. Bend and straiten the entire length of the cord bit by bit. The heater lamp should always be lit while doing so. If the heater lamp becomes intermittent the cord is faulty and should be replaced.

Note: the Heater lamp will blink if the temperature of the soldering iron tip has reached the set temperature i.e. 480°C. this is not an indication of a faulty cord.

### Test 2: Resistance test

1. Follow the steps in disassembling the hand piece .
2. Test for continuity between the pins and colored wires at the hand piece PCB, all matching contacts at the PCB and wires should register 0 to 2 Ω.

## TESTING THE HEATING ELEMENT

### To test if the heating element is in working condition:

Cool down assembly to room temperature before continuing the tests below:

1. Follow "*disassembling the hand piece*" guide.
2. Do the following tests on the hand piece PCB board:
  - ♦ Resistance value of heating element (RED) 18 — 23  $\Omega$
  - ♦ Resistance value of sensor (blue) 2.5 — 3.5  $\Omega$
  - ♦ After testing check results with the following:
  - ♦ If the resistance value is not as stated above replace the heating element.
  - ♦ If a 0  $\Omega$  or infinite resistances are measured check for shorts or open circuits.
  - ♦ Intermittent readings can also be caused by cold solder double check solder points if the heating element has recently been replaced.

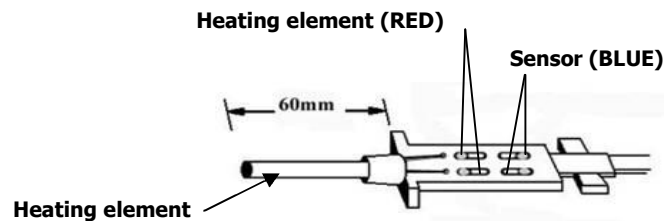

### Test the resistances of the following configurations at the 5 pin socket:

Pins 1 & 2	18 to 23 $\Omega$
Pins 4 & 5	2.3 to 3.5 $\Omega$
Pin 3 & solder tip	Below 2 $\Omega$



**5 Pin Socket**

## OPERATING INSTRUCTIONS

1. Follow procedures shown in the "Assembly Instructions".
2. Turn on the unit.
3. The Digital display will initially display the current set temperature, after a few seconds it would switch to displaying the actual temperature.
4. **For 937:** Turning the control knob clockwise increases the desired (SET) temperature settings, while turning the knob counter-clockwise decreases the desired (SET) temperature settings. The display would increase and decrease accordingly showing the SET temperature. If the knob is left unmoved, the display would switch from showing the SET temperature to showing the actual temperature at the tip of the soldering iron.
5. **For 937+:** Pressing the up button increases the desired (SET) temperature settings, while pressing the down button decreases the desired (SET) temperature settings. The display would increase and decrease accordingly showing the SET temperature. If the buttons are all depressed, the display would switch from showing the SET temperature to showing the actual temperature at the tip of the soldering iron. The button with the asterisk \* marking is used to quickly reset the device to the default temperature setting.
6. The display would show the letters "OFF" if the unit has detected that the soldering iron and the main unit are not connected securely or is not connected. If this is displayed, turn off the unit and reattach firmly the soldering iron to the receptacle at the main unit.

## SOLDER TIP CARE and MAINTENANCE

### Tip Temperature

If the tip temperature is too high, it decreases the life of the tip. So we suggest you to use the lowest \*possible\* tip temperature when soldering. This not only prolong life of the tip, it also quickens heat recovery and decreases harm to sensitive components.

### Cleaning

The soldering iron tip should be cleaned after use by wiping it on the damp sponge found in the soldering iron stand, this is to get rid of burnt solder or fluxes that causes oxidation on the tip. If the tip has oxidation, apply solder and wipe using the damp sponge, repeat these steps until oxidation is removed.

Regular cleaning is also needed when tips are used for prolonged period of time (remove tip from soldering iron and clean it once a week). The solder tips are chrome electroplated on the surface and should be bright silver with no flux residue or solder on it. If the tip shows disfiguration or has rust on it. Change the tip.

**⚠ Remember to tin the tip after cleaning in preparation for the next use.**

### When Not in Use

If a soldering iron does not have a thin consistent layer or solder over the entire surface, the tip has not been properly tinned. When you are not using your iron, make sure you leave a large lump of solder on the tip. This maintains the tinning on the tip, and the tip will last much longer. Many technicians mistakenly clean the tip before they put the iron into the holder. Leave the solder on the tip to protect it.

## HAND PIECE ASSEMBLY

### The hand piece may be disassembled for troubleshooting and repair:

1. Turn off main station and unplug from power source.
2. Detach the Soldering Iron Receptacle ("15") from the main unit.
3. Turn the Copper Nut, ("1") counter clockwise to loosen it.
4. Pull out the Tip Enclosure ("2"), the Solder Tip ("3" as ), and the Tip Lock ("4").
5. Turn the Plastic Nut ("5" ) counter clockwise to release it from the main body.
6. Push out the Heating Element ("6" ) via the wire Cord ("14" ).

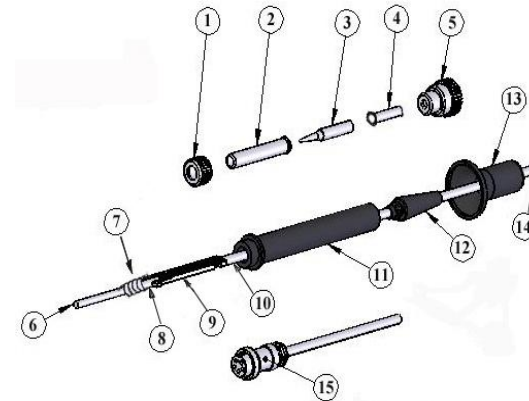

### Follow these steps to reassemble the hand piece:

1. Slide in hand piece PCB into the main handle. Be sure to secure the PCB in the notch at the mouth of the main handle.
2. Attach the front module "5" to the main handle.
3. Slide in the Tip holder "4". Make sure the smaller end is inserted first as seen in the illustration below.
4. Insert the soldering iron tip "3" as seen below.
5. Secure the tip by inserting the tip enclosure "2" and nut "1" securely.
6. Reattach the hand piece plug "15" to the receptacle at the main station.
7. Recalibrate the soldering iron, see guide on tip care and maintenance section of this manual.